

Mjerilo: 1:1	Datum: 11.05.20.	Prezime i ime: Žure Zlatko	Tehnička škola za strojarstvo i mehatroniku, Split
Pozicija: 1	Sastavni crtež broj:	Materijal:	
Broj crteža:		Izrada rupa i provrta s navojem u 3D (Inventor 2020)	

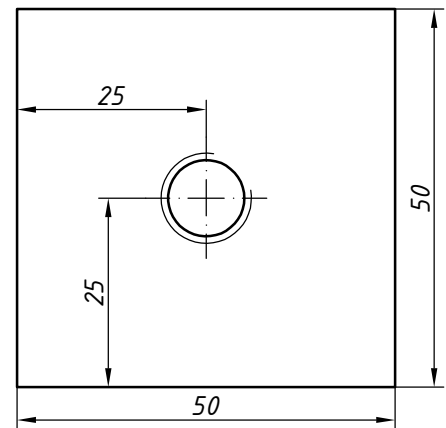
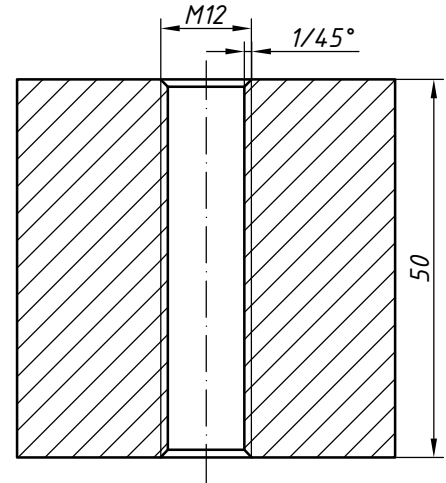

Mjerilo: 1:1	Datum: 11.05.20.	Prezime i ime: Žure Zlatko	Tehnička škola za strojarstvo i mehatroniku, Split
Pozicija: 1	Sastavni crtež broj:	Materijal:	
Broj crteža:		Izrada provrta s navojem u 3D (Inventor 2020)	